

Testing Resolvers Using a Precision Ratio Transformer

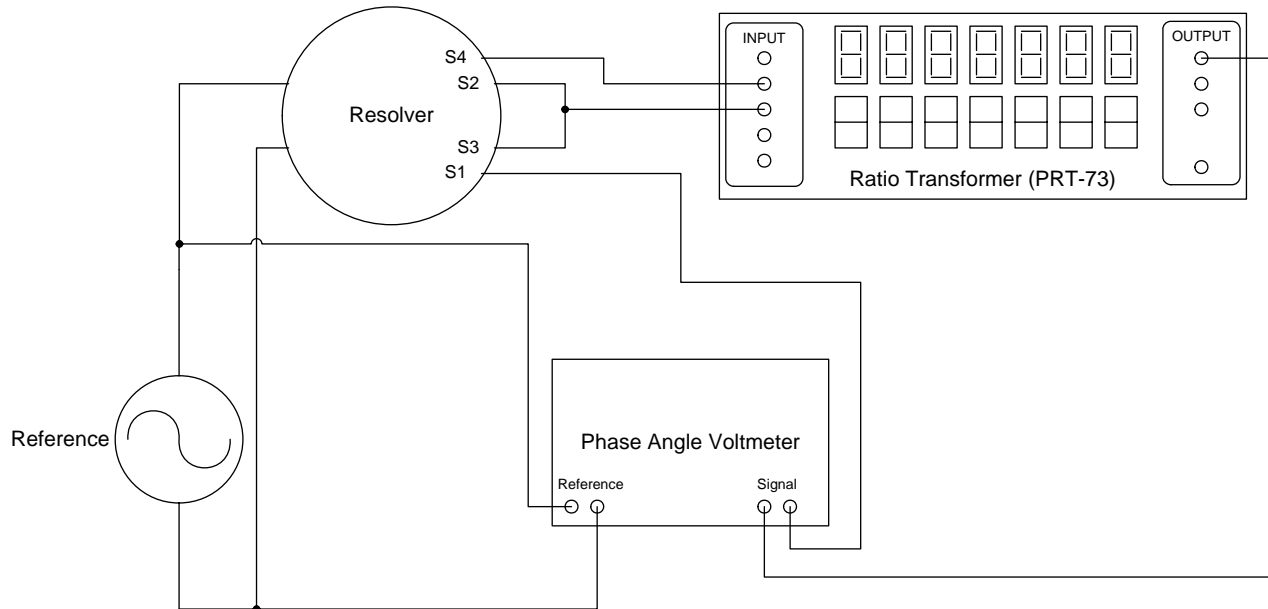

Figure 1 – Resolver Test Setup

Testing resolvers (also known as synchro resolvers) at very small angular increments or at better than 1 arc-second (.00028 degrees) accuracy requires a high precision instrument. A high precision ratio transformer can provide the accuracy and resolution needed for testing resolvers at small angular increments. This document discusses how a precision ratio transformer can be used as a standard for synchro resolvers.

To check the angular accuracy of a resolver the AC reference, resolver, ratio transformer and a phase angle voltmeter (PAV) are connected as shown in Figure 1. S4 of the resolver is connected to the input of the ratio transformer. S1 is connected to one of the PAV signal input terminals. S3 and S2 are connected to the common input of the ratio transformer. The shaft is precisely set to a known angle. The ratio transformer is an AC voltage divider; it is set to the tangent of the shaft angle. S4 is multiplied by the ratio setting of the ratio transformer. Since S4 is the cosine output of the

resolver, the output of the ratio transformer should equal the sine output.

$$\tan = \sin/\cos$$

OR

$$\sin = \tan * \cos$$

S1 is the sine output of the resolver; the output of the ratio transformer should equal the S1 output of the resolver. If the two outputs are equal, the PAV will indicate a null condition. If the PAV does not indicate a null condition, the setting of the ratio transformer is adjusted until a null condition is indicated. The arctangent of the ratio transformer setting is the angle that the resolver output is indicating. For example, if a resolver shaft were set to angle of 22.5°, the ratio transformer would be set to the tangent of 22.5° which is 0.4142136. The null meter does not indicate a null and the ratio transformer are adjusted until it does. The final setting of the ratio transformer is 0.4040262; the arctangent of that value is 22.0°. The resolver error is therefore 0.5°.

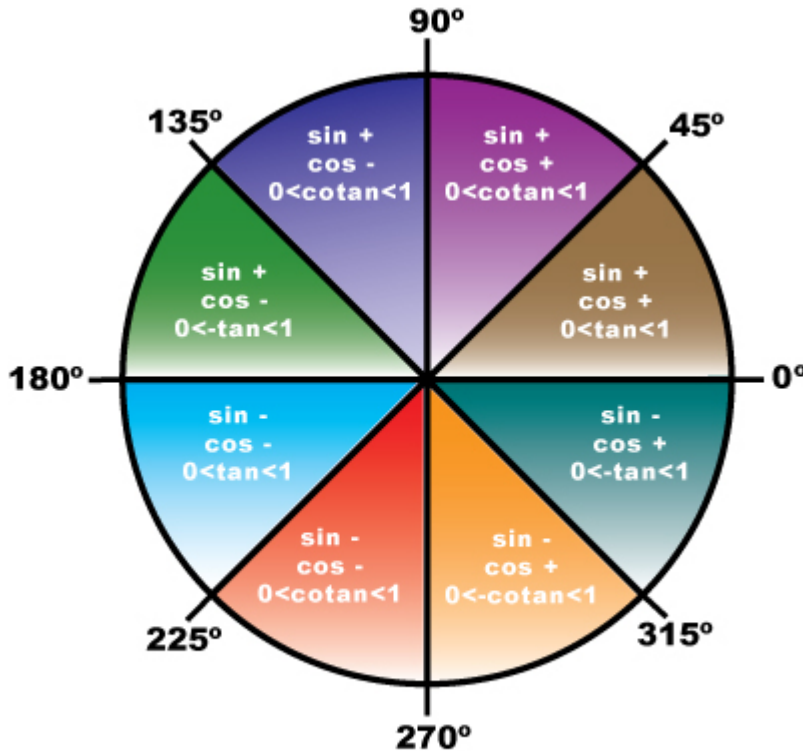

Figure 2 – Illustration of the relationship of the resolver outputs and ratio transformer settings at various angles.

The setup in Figure 1 only works for angles 0-45° and 180-225°. However, other angles can still be tested by changing the resolver output connections. There are two things to consider:

1) The output with the greater magnitude at a particular angle is connected to the input of the ratio transformer. That is because the setting of the ratio transformer (tangent of the shaft angle) must be ≤ 1 . The cosine is greater than the sine at 0° to 45°, so the tangent is ≤ 1 . At 45° to 90° the sine is greater so it is used as the input to the ratio transformer. The ratio transformer is set to the inverse of the tangent, or cotangent, because it is ≤ 1 . Refer to Figure 2.

2) The two outputs connected to the common of ratio transformer should have the same sign. At 0-90° both sine and cosine are positive, so S3 and S2 are connected to common. At 90-180° sine is positive and cosine is negative so S3 and S4 are connected to common. Refer to Figure 2.

Table 1 shows the connections for the resolver outputs and ratio transformer settings according to angle. In this table NM means input of Null Meter, C is the input Common of the ratio transformer and RT is the input of the Ration Transformer.

Angle	RT Setting	S1	S3	S4	S2
0 to 45	Tangent	NM	C	RT	C
45 to 90	Cotangent	RT	C	NM	C
90 to 135	-Cotangent	RT	C	C	NM
135 to 180	-Tangent	NM	C	C	RT
180 to 225	Tangent	NM	C	RT	C
225 to 270	Cotangent	RT	C	NM	C
270 to 305	-Cotangent	RT	C	C	NM
305 to 360	-Tangent	NM	C	C	RT

Table 1 – Connections required for testing resolvers at various angles.

Another thing to consider is how to orient the resolver to a known starting point. There may be a mechanical means of doing this for some resolvers. If not there is a means of orienting the resolver electrically. Using the connections shown in Figure 1, set the ratio transformer to all zeros. Then rotate the shaft of the resolver until there is a null reading on the null meter. This represents either 0° or 180°. Increase the shaft angle slightly. If the indicator on the phase angle voltmeter indicates a negative voltage, the resolver is electrically at 180°. If it indicates a positive voltage, the resolver is electrically at 0°.

The accuracy of the test will depend on many variables, like the accuracy and resolution of the phase angle voltmeter and the accuracy at which the shaft angle of the resolver is set. The accuracy of the ratio transformer will vary depending on the accuracy and resolution of the particular model. The accuracy of a specific model will often depend on ratio setting and frequency of the reference signal.

In Figure 1, a TEGAM Model PRT-73 is used. The PRT-73 can be controlled remotely via an IEEE-488 bus, which means this process can be automated, provided the other instruments required for the test can also be controlled remotely. The resolution of the PRT-73 is 0.1 ppm, which translates to an angular resolution of 0.0000057° or 0.02". The accuracy of the PRT-73 is dependant on the frequency of the reference and its setting. The worse case linearity specification at 50 to 1000 Hz for the PRT-73 is 0.9 ppm, which is better than 0.2" angular accuracy.



Figure 3 – TEGAM's Model PRT-73 Precision Ratio Transformer tests synchro resolvers at better than 1 arc-second (.00028 degrees) accuracy.

This method can be a very accurate and precise method of testing resolvers. Furthermore, using instruments that can be controlled remotely, like the TEGAM PRT-73, this process can be automated. In addition to the PRT-73, TEGAM offers a full line of manually operated ratio transformers and resolver simulators and standards. 